



SANYO HVAC (Division of SANYO Commercial Solutions)

Think GAIA  
For Life and the Earth





SANYO HVAC is recognized as a world leader in split-air conditioning technology. Our focus on efficiency and reliability demonstrates our commitment to our customers and our planet.

**ECOi Technical  
Tips**

## Outdoor Unit Lineup

		Model	Cooling BTU	Heating BTU	Max# ID Units	DB	208/230V
<b>M I N I</b>	CHX03652	<b>03652</b>	<b>38,200</b>	<b>42,700</b>	<b>6</b>	<b>54.5</b>	<b>1PH 30A</b>
	CHX06052	<b>06052</b>	<b>52,900</b>	<b>60,000</b>	<b>9</b>	<b>55</b>	<b>1PH 50A</b>
<b>W M U L T I</b>	CHDX09053 or CHDZ09053	<b>09053</b>	<b>95,500</b>	<b>107,500</b>	<b>16</b>	<b>60</b>	<b>3PH 60A</b>
	CHDX14053 or CHDZ14053	<b>14053</b>	<b>153,600</b>	<b>170,600</b>	<b>26</b>	<b>61</b>	<b>3PH 80A</b>

		Model	Cooling BTU	Heating BTU	Max# ID Units	DB	208/230V
<b>W M U L T I</b>	 090 + 090	<b>20053</b>	<b>191,100</b>	<b>215,000</b>	<b>33</b>	<b>60+60</b>	<b>3PH 120A</b>
	 090 + 140	<b>23053</b>	<b>249,100</b>	<b>278,100</b>	<b>40</b>	<b>60+61</b>	<b>3PH 140A</b>
	 140 + 140	<b>32053</b>	<b>307,100</b>	<b>341,200</b>	<b>40</b>	<b>61+61</b>	<b>3PH 160A</b>

# Indoor Unit Power Requirements

All Eco-I indoor units require a 208/230 VAC single phase power supply. Each indoor unit should be supplied with a field supplied disconnect switch.

Ex: Typical Wiring Connections at Indoor Unit

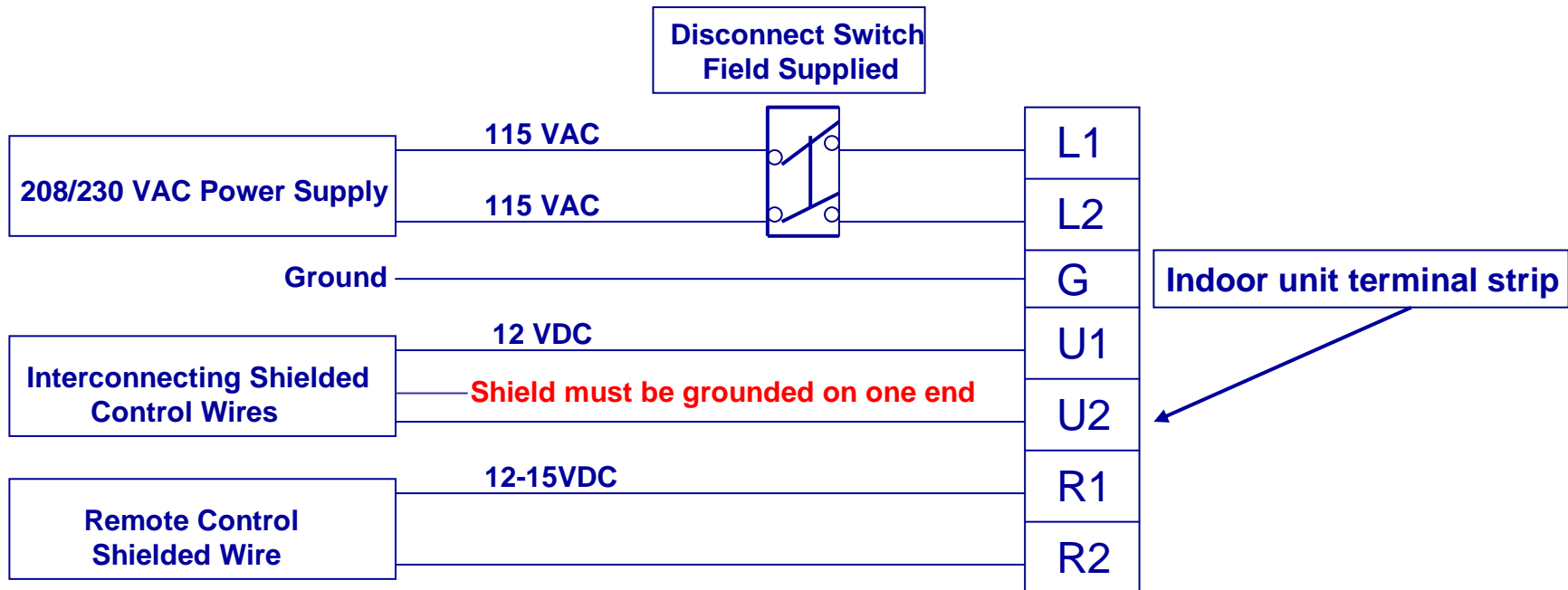

1. Measure the voltage of each phase to ground. For example:
  - a. L1 to Ground = 123 Volts
  - b. L2 to Ground = 217 Volts (this would be the wild leg)
  - c. L3 to Ground = 123 Volts
2. Measure phase to phase to insure acceptable voltages. For example:
  - a. L1 to L2 = 249 Volts
  - b. L1 to L3 = 249 Volts
  - c. L2 to L3 = 249 Volts

#### Corrective Actions:

1. Connect the "wild leg" to the "L3" (or "T") power supply terminal of the outdoor unit. Connect the other two phases to L1 and L2.
2. Reapply power to the outdoor unit.
3. If the system still fails to operate or to allow initiation of the Auto Address function a "reverse phase" may be causing the problem. If so, turn power off and reverse the wires attached to L1 and L2.
  - a. Note: Reverse phase may also be indicated by the fault code "P05".

For additional details please access our technical literature using our website at [www.sanyohvac.com](http://www.sanyohvac.com) or contact our technical service department at 800-851-1235.

# Power Requirements for Mini-Eco-I 3 & 5 Ton

## 5-2. Recommended Wire Length and Wire Diameter for Power Supply System

### Outdoor unit

Type	(A) Power supply wiring	Time delay fuse or circuit capacity
CHX03652	For field wiring rules, please refer to your LOCAL ELECTRICAL CODES	30 A
CHX06052		50 A

### Indoor unit

Type	(B) Power supply wiring	Time delay fuse or circuit capacity
K	For field wiring rules, please refer to your LOCAL ELECTRICAL CODES	15 A
A, X, T, U		15 A
D		15 A

### Control wiring

(C) Inter-unit (between outdoor and indoor units) control wiring	(D) Remote control wiring	(E) Control wiring for group control
AWG #18 (0.75 mm <sup>2</sup> ) Use shielded wiring*	AWG #18 (0.75 mm <sup>2</sup> ) Use shielded wiring	AWG #18 (0.75 mm <sup>2</sup> ) Use shielded wiring
Max. 3,280 ft.	Max. 1,640 ft.	Max. 1,640 ft. (Total)

### NOTE

\* With ring-type wire terminal.

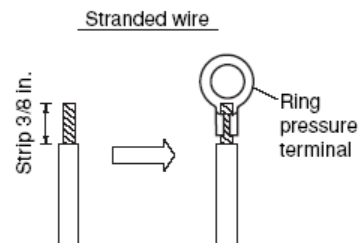

# Ex: Proper Grounding of 18-2 Shielded Cable

\* Change in Shield grounding procedure  
Ground Shield only one end

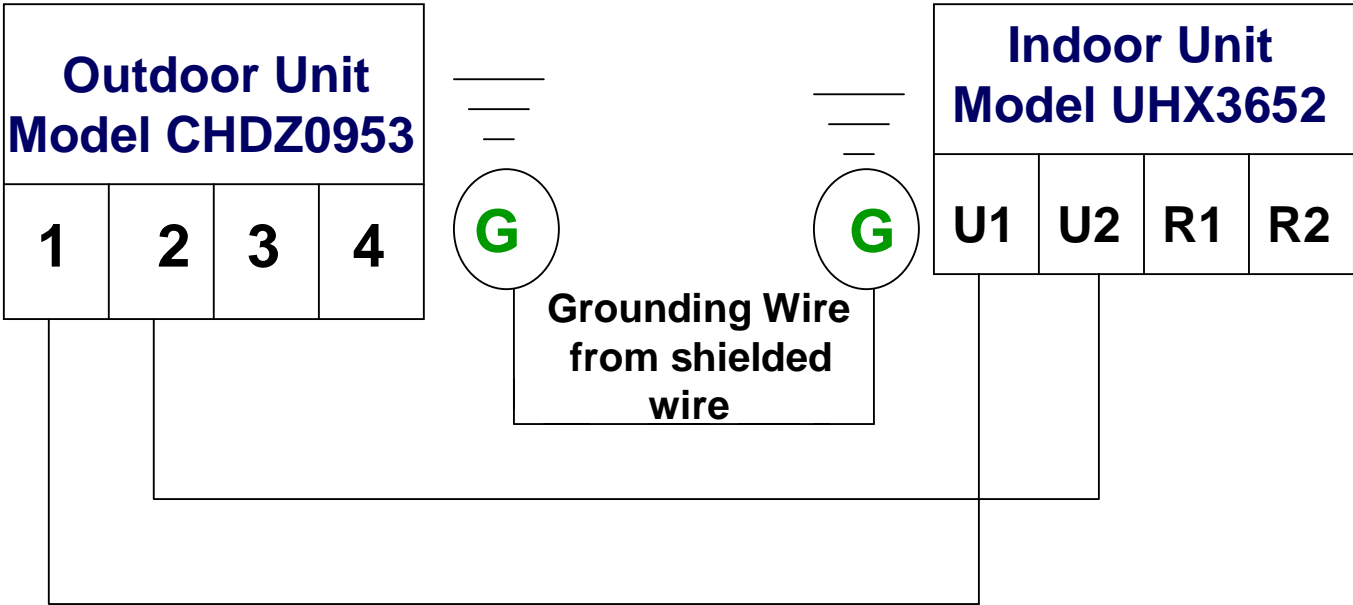

18-2 Shielded Wire

## Inter-Units control wiring : Not polarity

⇒ ***Do not connect such as star wiring.***

☆ : Star wiring

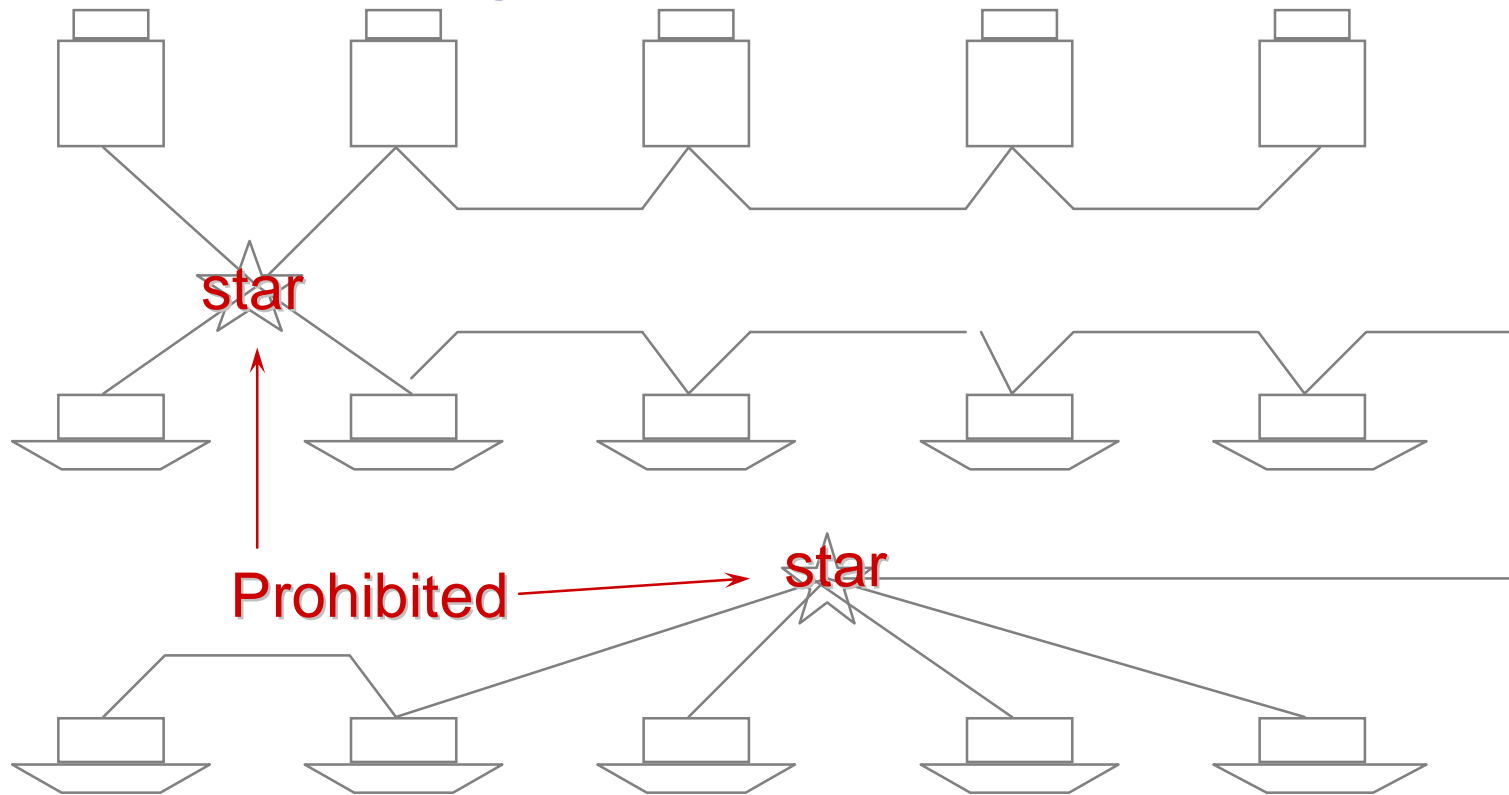

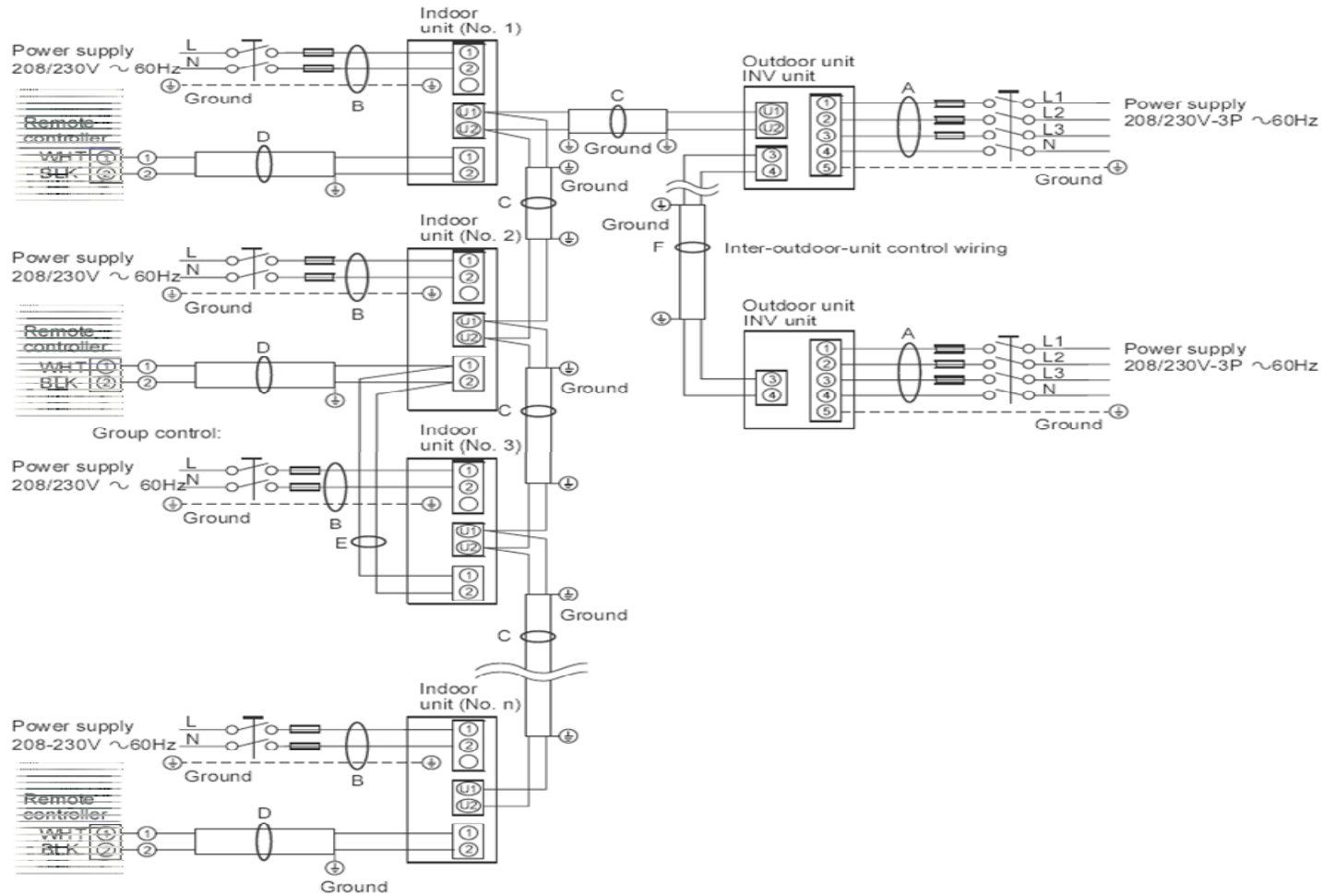

- Change in Shield grounding procedure
- Ground Shield only one end

## Control wiring

(C) Inter-unit (between outdoor and indoor units) control wiring	(D) Remote control wiring	(E) Control wiring for group control
AWG #18 Use shielded wiring*	AWG #18 Use shielded wiring	AWG #18 Use shielded wiring
Max. 3,280 ft.	Max. 1,640 ft.	Max. 1,640 ft (Total)

### NOTE

\* With ring-type wire terminal.

### (F) Inter-outdoor unit control wiring

AWG #18  
Use shielded wiring  
Max. 1,640 ft.

**(5) Use shielded wires for inter-unit control wiring (c) and ground the shield on both sides, otherwise misoperation from noise may occur. (Fig. 4-4) Connect wiring as shown in Section “4-3. Wiring System Diagram.”**

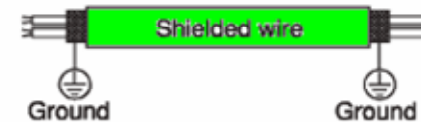

Fig. 4-4



### WARNING

Loose wiring may cause the terminal to overheat or result in unit malfunction. A fire hazard may also exist. Therefore, ensure that all wiring is tightly connected.

When connecting each power wire to the terminal, follow the instructions in “How to connect wiring to the terminal” and fasten the wire securely with the fixing screw of the terminal plate.

- Change in Shield grounding procedure
- Ground Shield only one end

## Installing Distribution Joint

The direction of the distribution joint kit should be horizontal or vertical.

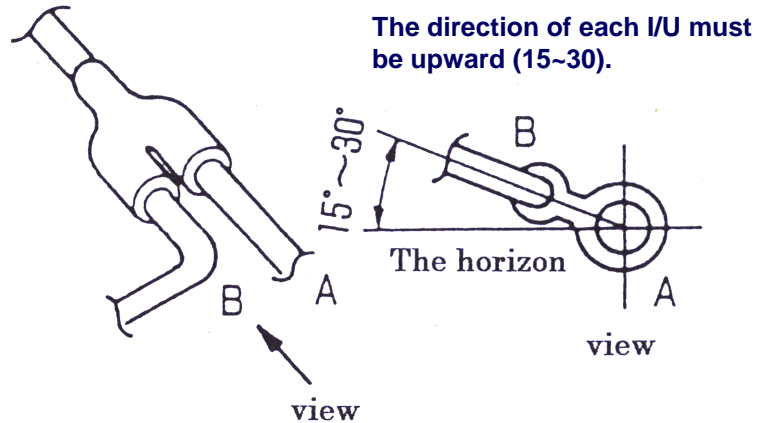

- It is suggested that soft-drawn, ACR grade tubing be used in all cases to minimize equivalent length of tubing run, and leak potential.
- Hard-drawn tubing may be used, if necessary, with long radius elbows.
- 15% silver brazing material is recommended on all solder joints.
- Factory supplied distribution joints (purchased separately) must be used where specified.
- Field installed ball valves, with access ports, are recommended on both branch lines to an indoor unit.



# Maximum Tubing Lengths

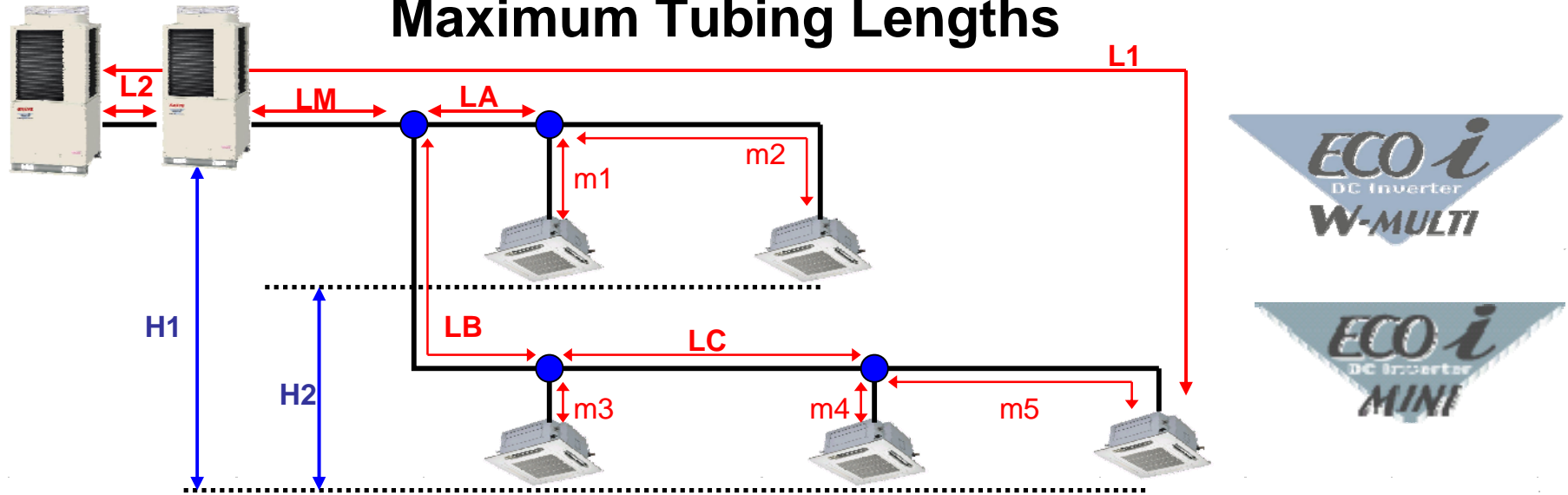

Items	Reference	Contents		Length (feet)	
				Mini Eco-i	W-Multi
Allowable tubing length	L1	Max tubing length	Actual length	≤ 492	≤ 492
			Equivalent length	≤ 574	≤ 574
	m1~m5	Max. length of each distribution joint		≤ 98	≤ 98
	LM	Max. main piping length		≤ 262	≤ 262
	LM+LA+~LC +m1+~m5	Total max. tubing length including length of each distribution joint		≤ 656	≤ 984
Allowable elevation difference	H1	When outdoor unit installed higher		≤ 164	≤ 164
		When outdoor unit installed lower		≤ 131	≤ 131
	H2	Max. difference between indoor units		≤ 50	≤ 50

## Refrigerant Pre-Charge Amount

The refrigerant charge shipped with the condenser from the factory is what is needed for the condenser section only. Once additional piping is installed to the system it will become necessary to add an additional amount of refrigerant. This calculation is figured out by measuring the sizes and distances of the total length of liquid line piping installed in feet . All liquid line sizes must be considered.

- Precautions for brazing

Be sure to replace the air inside the tube with nitrogen to prevent oxide film from forming during the brazing process. Be sure to use a damp cloth or other means to cool the valve unit during brazing.

**Work method**

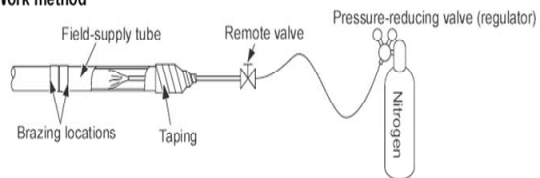

**CAUTION**

1. Be sure to use nitrogen. (Oxygen, CO<sup>2</sup>, and CFC must not be used.)
2. Use a pressure-reducing valve on the nitrogen tank.
3. Do not use agents intended to prevent the formation of oxide film. They will adversely affect the refrigeration oil, and may cause equipment failure.
4. The balance tube is not used if only 1 outdoor unit is installed. Use the unit in the same conditions as when it was shipped from the factory.

## Calculating Additional Refrigerant Charge

- The outdoor unit is shipped with just enough refrigerant for only the condenser section.
- Once all refrigerant piping is completed, the total length of liquid line in feet must be calculated. This will determine the additional amount of refrigerant needed.

**Example: (1) CHDX14053 Outdoor Unit  
(12) KHX1252 Indoor Units**

**Total Length of Liquid Line Ran 300'**

**100' of 1/2" (Additional amount in Oz./Ft. 1.38)**

**100' of 3/8" (Additional amount in Oz./Ft. 0.602)**

**100' of 1/4" (Additional amount in Oz./Ft. 0.279)**

**Multiply the total length of each size liquid line by its adjustment factor, this will give each additional amount in ozs.**

**100' X 1.38 = 138 ozs.**

**100' X 0.602 = 60.20 ozs.**

**100' X 0.279 = 27.90 ozs.**

---









**226.10 ozs.**

**226.10 ozs.  $\div$  16 = 14.1 LBS. Additional Charge**



● **Examples of the No. of indoor units settings (S005, S004)**

No. of indoor units	Indoor unit setting (S005) (3P DIP switch, blue) 10 20 30	Indoor unit setting (S004) (Rotary switch, red)
1 unit (factory setting)	All OFF 	 Set to 1
11 units	1 ON 	 Set to 1
21 units	2 ON 	 Set to 1
31 units	3 ON 	 Set to 1
40 units	1 & 3 ON 	 Set to 0

● **Examples of refrigerant circuit (R.C.) address settings (required when link wiring is used) (S003, S002)**

System address No.	System address (S003) (2P DIP switch, blue) 10 20	System address (S002) (Rotary switch, black)
System 1 (factory setting)	Both OFF 	 Set to 1
System 11	1 ON 	 Set to 1
System 21	2 ON 	 Set to 1
System 30	1 & 2 ON 	 Set to 0



● **Examples of the No. of outdoor units settings (S006)**

No. of outdoor units	Outdoor unit setting (S006) (3P DIP switch, blue)
1 unit (factory setting)	1 ON 
2 units	2 ON 
3 units	1 & 2 ON 

● **Address setting of main outdoor unit (S007)**

Unit No. setting	Address setting of outdoor unit (S007) (3P DIP switch, blue)
Unit No. 1 (main unit) (factory setting)	

● **Address setting of sub outdoor unit**

Unit No. setting	Address setting of outdoor unit (S007) (3P DIP switch, blue)
Unit No. 2 (sub unit) (factory setting)	2 ON 
Unit No. 3 (sub unit)	1 & 2 ON 

## Summary of Rotary Dials and Dip Switch Settings

**(CN100) A.ADD Pins:** These pins are used to initiate auto addressing procedure. (8 & 12 Ton)

**(CN51) A.ADD Pins:** These pins are used to initiate auto addressing procedure. (3 & 5 Ton)

**(S002):** Outdoor system address setting switch. Black Knob

**(S003):** Dip switch setting when outdoor system address exceeds 9 outdoor units.

**(S004):** Switch setting for the number of indoor units hooked up to the outdoor unit. Red Knob

**(S005):** Dip switch setting when indoor unit address exceeds 9 indoor units.

**(S006):** Identifies outdoor unit as #1 or #2 in the case units are piped together as one.

**(S007):** Determines which system is the Main unit and which is the Sub unit.

**(S010):** Identifies how to switch between inverter compressor and constant volume compressor in the event of a failure of either compressor.

**(Terminal Plug):** Used when outdoor unit S-Net wiring is linked between outdoor units.

**(LEDS 1 & 2):** These LEDES blink alternately when auto address process is initiated.  
These LEDES can also be used to determine error codes.

**(D53):** This LED will be lit when power is being applied to the outdoor board.

**(Run CN103):** These pins when shorted will Start all indoor units within that refrigerant circuit.

**(Stop CN104):** These pins when shorted will Stop all indoor units within that refrigerant circuit.

**(AP CN102):** These pins when shorted will turn on all solenoid valves for vacuuming of of the system.

**(Mode CN101)** These pins when shorted will change modes from Heating to Cooling.

**(Test CN022)** These pins are used by the factory to test the outdoor PCB at the factory.